



580-A
OPERATORS HANDBOOK
WD66-580A-M0903

Tanco Autowrap Ltd.
Royal Oak Road
Bagenalstown
Co. Carlow
Ireland

Tel.: +353 (0)5997 21336
Fax: +353 (0)5997 21560
E-Mail: info@tanco.ie
Internet: www.tanco.ie



GUARANTEE

Subject to hereunder provided, the sellers undertake to correct either by repair or at their election by replacement any defect of material or workmanship which occurs in any of its goods within twelve months after delivery of such goods to first user, with the exception of contractors or commercial users when warranty period is six months. In respect of Autowraps the warranty period is for 12 months or 8000 bales, whichever occurs first. In respect of Aerways, tine breakage will be assessed on an individual basis in every case.

The term goods when used in this document means the article or articles described in invoices as sold by the sellers but does not include equipment or proprietary parts or accessories not manufactured by the sellers. The sellers, however, undertake to pass on so far as they legally can to the first user the benefit of any warranty given to the sellers by the suppliers of such equipment, parts or accessories.

This understanding shall not apply to:-

- (a) Any goods that have been sold by the first user.
- (b) Any goods which have been injured by unfair wear and tear, neglect or improper use.
- (c) Any goods the identification marks of which have been altered or removed.
- (d) Any goods that have not received the basic normal maintenance such as tightening of bolts, nuts, tines, hose connections and fittings and normal lubrication with the recommended lubricant.
- (e) The use of any product on tractors exceeding the recommended horsepower.
- (f) Any goods that have been altered or repaired other than on instruction or with the written approval of the seller or to which any part not manufactured or having written approval by the sellers have been fixed.
- (g) Any second-hand goods or parts thereof.

Any allegedly defective part or parts returned to the seller must be sent carriage paid. No claim for repair or replacement will be entertained unless upon discovery of the alleged defect written notification is sent to the Sellers giving, at the same time, the name of the Buyer from whom the goods were purchased and the date of purchase, together with the full details of the alleged defect and the circumstances involved, also the serial number of the machine etc.

The sellers shall be under no liability to their Buyers and first or subsequent users of their goods or to any other person or persons for loss or damage howsoever arising in respect of either personal injuries or for arising out of, or in any other way connected with or arising from the manufacturer's sale, handling, repair, maintenance, replacement or use of its goods or the failure or malfunction of any of its goods.

Representation and/or warranties made by any persons (including Buyers and employees and other representatives of the Seller) which are inconsistent or conflicting with these conditions are not binding upon the sellers unless given in writing and signed by a director of sales.

CLAIMS

If you wish to make a claim under the guarantee:

- 1: Immediately, stop using the machine.
- 2: Photocopy and fill out the warranty claim form attached to the back of this manual. List the details of the machine, its serial number and the part number of the damaged part.
- 3: Consult with your Tanco dealer (supplier) and have him forward your claim and the damaged item to Tanco.



Tanco Autowrap Model 580-A 2004 WD66-580-A-M0903

Table of Contents

| | | |
|-----|--|----|
| 1. | General Safety Recommendations | 4 |
| | 1.1. Safety instructions | 7 |
| | 1.2. Safety Decals | 8 |
| 2. | Technical Specifications | 9 |
| 3. | Pre-delivery instructions | 10 |
| 4. | Transport Instructions | 16 |
| 5. | Machine Identification | 16 |
| 6. | Preparation of New Machine | 16 |
| 7. | Electrical Circuit Diagram 580-A | 17 |
| 8. | Controller Manual 580-A | 18 |
| 9. | Mode of Operation 580-A | 25 |
| 10. | Film overlap system | 27 |
| 11. | Service & maintenance | 28 |
| 12. | Technical Diagrams | |
| | 12.1. Film Threading Diagram | 30 |
| | 12.2. Gear Box chain drive tensioning system | 31 |
| | 12.3. Turntable Chain Drive tensioning system | 32 |
| | 12.4. Bale Ramp Cylinder-recharging instruction | 33 |
| | 12.5. Cut & Start Cylinder – recharging cylinder | 34 |
| 13. | Hydraulic Circuit Diagram 580-A | 35 |
| 14. | Closed Centre Conversion 580-A | 36 |
| 15. | Fault Finding | 37 |
| 16. | Warranty claim form. | 39 |
| 17. | Declaration of Conformity | 40 |



1. GENERAL SAFETY RECOMMENDATIONS

Before operating the machine, always ensure that the tractor and machine meet with work safety and road traffic regulations.

Basic Principles

1. In addition to recommendations given in this manual, legislation on work safety and accident prevention must also be respected.
2. Advice is indicated on the machine, specifying safety recommendations in order to prevent accidents.
3. Before travelling on public roads, the operator must ensure that the machine conforms to road traffic regulations.
4. Before starting work, the operator must be familiar with all the machine controls, handing devices and their functions. Once at work, it is too late to do this!
5. Do not wear loose clothing, which could become caught up in moving elements.
6. The tractor should be equipped with a safety cab.
7. Before starting up the machine and begin work, check the surrounding area (beware of children!). Make sure there is sufficient visibility. Keep all people and animals away from the danger zone of the machine (risk of protection!!).
8. Carrying people or animals on the machine when working or transport is strictly forbidden.
9. Machine must only be attached to tractor using means provided and in accordance with current Safety standards.
10. Special care should be taken when attaching or removing the machine from the tractor.
11. Before transporting the machine on public roads, ensure that all legally required guards and indicators (lights, reflectors...) are in place and in good operations.
12. All operating controls (cords, cables, rods etc.) must be positioned so that they cannot be set off accidentally, risking accident or damage.
13. Before travelling on public roads, put the machine into it transport position as instructed in this operator's manual.
14. Never leave the tractor seat while the machine is operating.
15. Drive speed must be adapted to ground conditions as well as to roads and path. Always avoid abrupt changes of directions.
16. Before operating the machine, ensure that all safety guards are firmly in place and in good condition. If worn or damaged, replace immediately
17. Before operating the machine, check the tightness of all nuts and bolts, particularly on fixing elements (blades tines, knives, spades etc.).
18. Keep clear of the machine operating area.
19. **Warning!** Danger of crushing and shearing can exist when components are operated by hydraulic or pneumatic controls.



Tanco Autowrap 580-A
Operator's manual

20. Before leaving the tractor or before adjusting, maintaining or repairing the machine, turn off the engine, remove the ignition key and wait until all moving parts have come to a complete stop.
21. Do not stand between the tractor and the machine unless the hand break is tight and/or stops have been placed under the wheels.
22. Before any adjustments, maintenance or repairs are carried out, ensure that the machine cannot be started up accidentally.

SAFETY RECOMMENDATIONS FOR ATTACHING IMPLEMENTS TO TRACTOR

1. When attaching or removing the machine from the tractor, position hydraulic lift control lever in such a way that it cannot be set off accidentally.
2. When attaching the machine to the tractor hydraulic linkage, ensure that diameter of the link pins corresponds to the diameter of the ball joints.
3. **Warning!** Danger of crushing and shearing can exist in the lifting zone of the tractor hydraulic linkage!
4. Do not stand between the tractor and the machine when operating the outer lever of the lift mechanism.
5. In transport, the machine lift mechanism should be stabilized by the tractor tie rods, to avoid floatation and side shifting.
6. When transporting the machine, lock the hydraulic lift control lever in place so that it cannot be lowered accidentally.



HYDRAULIC SYSTEMS

1. **Warning!** Hydraulic system is under pressure.
2. When fitting hydraulic motors or cylinders, ensure that connections have been made correctly, as per manufactures instructions.
3. Before connecting hoses to the tractor hydraulics, ensure that tractor and machine circuits are not under pressure.
4. It is strongly recommended that the operator marks the hydraulic connections between tractor and machine to avoid making a wrong connection.
Warning! Functions could be reversed (For example: lift/lower)
5. Check hydraulic hoses regularly! Worn or damaged hoses must be replaced immediately. Replacement parts must be in accordance with the manufactures recommendations concerning specifications and quality.
6. Should a leak be found, take all necessary precautions to avoid accidents.
7. Any liquid under pressure (particularly oil from hydraulics) can be penetrate the skin and cause severe injury. If injured, see a doctor immediately, there could be a danger of infection.
8. Before any adjustments, maintenance or repairs are carried out, lower the machine, depressurize the circuit, turn off the engine and remove the ignition key.

MAINTENANCE

1. Before checking for any machine malfunction and before adjusting, maintaining or repairing the machine turn off engine and remove ignition key.
2. Check tightness of nuts and bolts regularly. Retighten if necessary.
3. If the machine is raised, prop it up in a stable position before carrying out any maintenance work
4. When replacing a work part, wear protective gloves and use only standarized tools.
5. It is forbidden to discard any oil, grease or filters. These must be given to waste disposal organisations to protect the environment.
6. Disconnect power source before any work is done to the electric system.
7. Check safety guards regularly, particularly those that are subject to wear. Replace immediately if damaged.
8. Spare parts used must be in accordance with specifications and standards as defined by the manufacturer. Use only genuine TANCO parts.
9. Before any electric welding is carried out on tractor or attached machine, disconnect generator and battery terminals.
10. Repairs on elements under pressure or tension (spring, accumulators etc.), must only be carried out by competent persons with standardised equipment.



1.1. SPECIAL SAFTY INSTRUCTIONS

1. Stop engine of the tractor before working on machine.
2. Put a suitable prop under raised platform before working in this area.
3. Always raise lift Arm and fit safety prop before transporting machine on public roads.
4. Lift Arms should always be lowered before operating turntable.
5. Ensure platform rollers are parallel to Lift Arm before arm is raised.
6. On Autowrap models fitted with hydraulic bale ramp it is essential that the hydraulic hose is not disconnected from the hydraulic cylinder or hydraulic accumulator. This system is charged under pressure. Also, do not attempt to open the hydraulic accumulator as this is a pressurised unit.

OPERATING SAFETY INSTUCTIONS

1. Operators should have their hands on the controls at all times when the machine is in use.
2. Autowrap control unit and level controls must remain in the tractor cap at all times. The operator must at no time leave the tractor cab when the machine is in motion.
3. Keep onlookers clear of machine at all times. Danger zone is 5 meters.
4. Beware of rotating turntable and all moving parts.
5. If not operated correctly the bale could fly off the turntable. The end support rollers must always be fitted. Do not exceed recommended turntable speed of 30 r.p.m. Mis-shapen bales combined with excessive turntable can be dangerous.
6. Care must be taken when tipping bales from the machine on sloping ground and during subsequent handling to ensure that they do not roll, thus causing hazard.

THINK OF YOUR PERSONAL SAFETY AND THAT OF OTHERS AT ALL TIMES

1.2. SAFETY DECALS

The following safety decals have been placed on your machine in the areas indicated. They are intended for your personal safety and for the safety of the other people working with you. Walk around your machine and note the content and locations of these warning signs. Review these decals and the operating instructions in the manual with your machine operators. Ensure that these decals are always legible. If they are not, replace them.

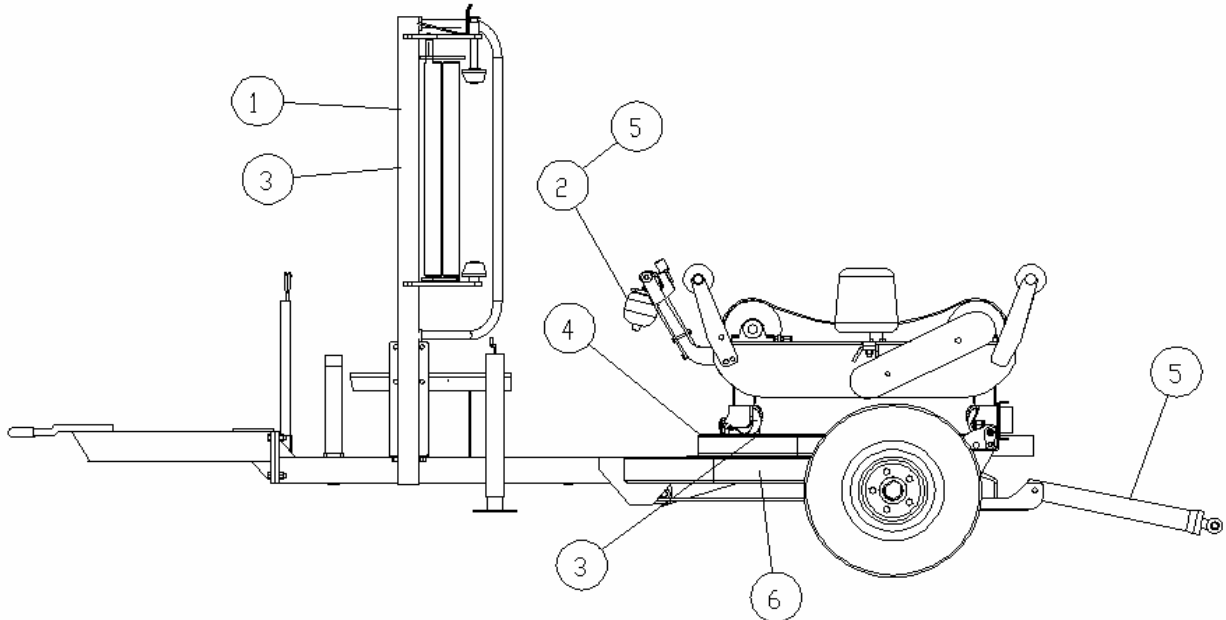

1. READ OPERATORS
MANUAL AND SFETY
INSTRUCTOONS

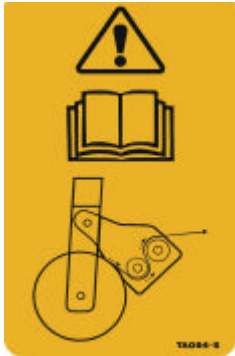

2. WARNING:
SHARP BLADE

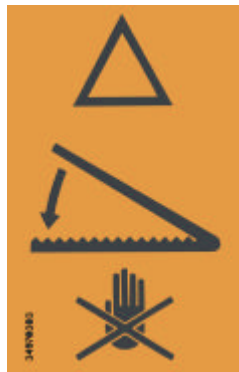

3. DANGER STAND
CLEAR



4. DO NOT EXCEED TURNTABLE SPEED OF 30 R.P.M.



5. BEWARE: HOSES UNDER PRESSURE AT ALL TIMES





6. ENSURE THAT NUTS
ARE KEEP TIGHT

2. TECHNICAL SPECIFICATIONS

| Dimensions | 580A/580S Models Trailed |
|--|---|
| Total length – Excluding Bale Ramp | 350cm |
| Width – excluding lift arm | 221cm |
| “ - lift arm fully raised | 243cm |
| “ - lift arm lowered | 380cm |
| Height to top of side (bale guide) rollers | 110cm |
| Height to top of lift arm | 242cm |
| | |
| Weight | |
| With lift arm | 1080kgs |
| Without Lift arm | 960kgs |
| | |
| Wheels | |
| Size | 10-80. 12 |
| Pressure | 42 p.s.i. |
| | |
| Lift arm capacity – Axle extended normally | 750kgs |
| “ “ “ - Axle extended Fully | 1000kgs |
| | |
| Speed of turntable | 30 rev/min* |
| Oil requirement | (165kpcm ²) 25 lit/min |
| | |
| Attachment to tractor | Tractor Hitch |
| | |
| Bale size | 120 x 120 cm up to 150 x 150 cm max weight of 1000kgs |
| | |
| Film (Width of Roll) | 750mm Optional 500mm |

* The speed of rotation can be varied to suit various conditions but on no account should it exceed 30 r.p.m. (Speed in excess of 30 r.p.m. will void warranty).



3. PRE-DELIVERY INSTRUCTIONS

IMPORTANT:

DO NOT ATTEMPT TO OPERATE THE MACHINE UNTIL THE FOLLOWING INSTRUCTIONS ARE PERFORMED. OTHERWISE SERIOUS DAMAGE COULD BE CAUSED.

3.1. MACHINE ASSEMBLY

For ease of transportation some items are removed from their positions and stored elsewhere on the machine. The bale ramp cylinder and Cut & Start unit are stored under the bale belt. On trailed models the cable guide is stored under the bale belt while on 3 point linkage models the top link bracket is stored under the belt. Also stored under the belt, on dispatch, is the **wrappers control unit. It is very important that this be removed from the machine and stored in a safe and dry place.** On remote control machines the rear support legs, infra-red receiver, sender units and warning beacon are also stored under the belt. The dispenser mast mounting bracket, film transport bracket, film pull down arm and hitch are attached to the front of machine. On round bale machines only, the top rollers c/w mounting brackets and the plastic end rollers are mounted on the turntable using temporary brackets. Road wheels, dispenser mast, bale lift arm and bale ramp are transported separately. Remove the above items and assemble as detailed on adjoining sketches and parts list taking particular note of the following points:

3.2. DISPENSER MAST

Attach dispenser mast and mounting bracket to front of machine. Attach the film pull down arm. Ensure the pull down arm is faced towards the machine. On remote control machines, attach the infra red receiver and warning beacon to top of the mast. The film mast height is adjustable. Its height is dependent on bale size and type and is set in field. It should be set so that centre line of films is in line with the centre of the bale. See Fig. 1 (Film threading diagram)

3.3. CUT & START

Attach Cut & Start unit to mounting frame on the left hand side of the machine. It is possible to move the unit along the mounting frame. Connected the hose which is attached to the mounting frame to the hydraulics ram on the cut & Start unit.

3.4. BALE LIFT ARM

Assemble bale lift arm attach to mounting points on the right hand side of the main chassis. Attach hydraulic ram to lift arm. Grease pivot points.

3.5. TOP ROLLERS AND PLASIC END ROLLERS

Attach plastic end rollers to mounting points on the back and front of the turntable. On round bale machines only, attach top rollers and mounting brackets to each side of the machine.

3.6. ROAD WHEELS

Attach road wheels ensuring that nuts are tight and tyre pressure is 50 p.s.i.

3.7. BALE RAMP OR MAT

Attach bale ramp or mat to rear chassis. Note: Round bale trailed models have hydraulic bale ramps with an option of end tip bale ramp. Linkage mounted machines have bale mats. The standard 1080 trailed models have hydraulic bale ramps. SEE INSTRUCTION BELOW FOR FITTING HYDRAULIC BALE RAMP.

Checks to be performed

1. Check that all bolts and nuts are tight.
2. That all lubrication points are greased.
3. Check that all guards are in place.
4. Check all operating and safety stickers are in place.

Instructions for fitting hydraulic bale ramp

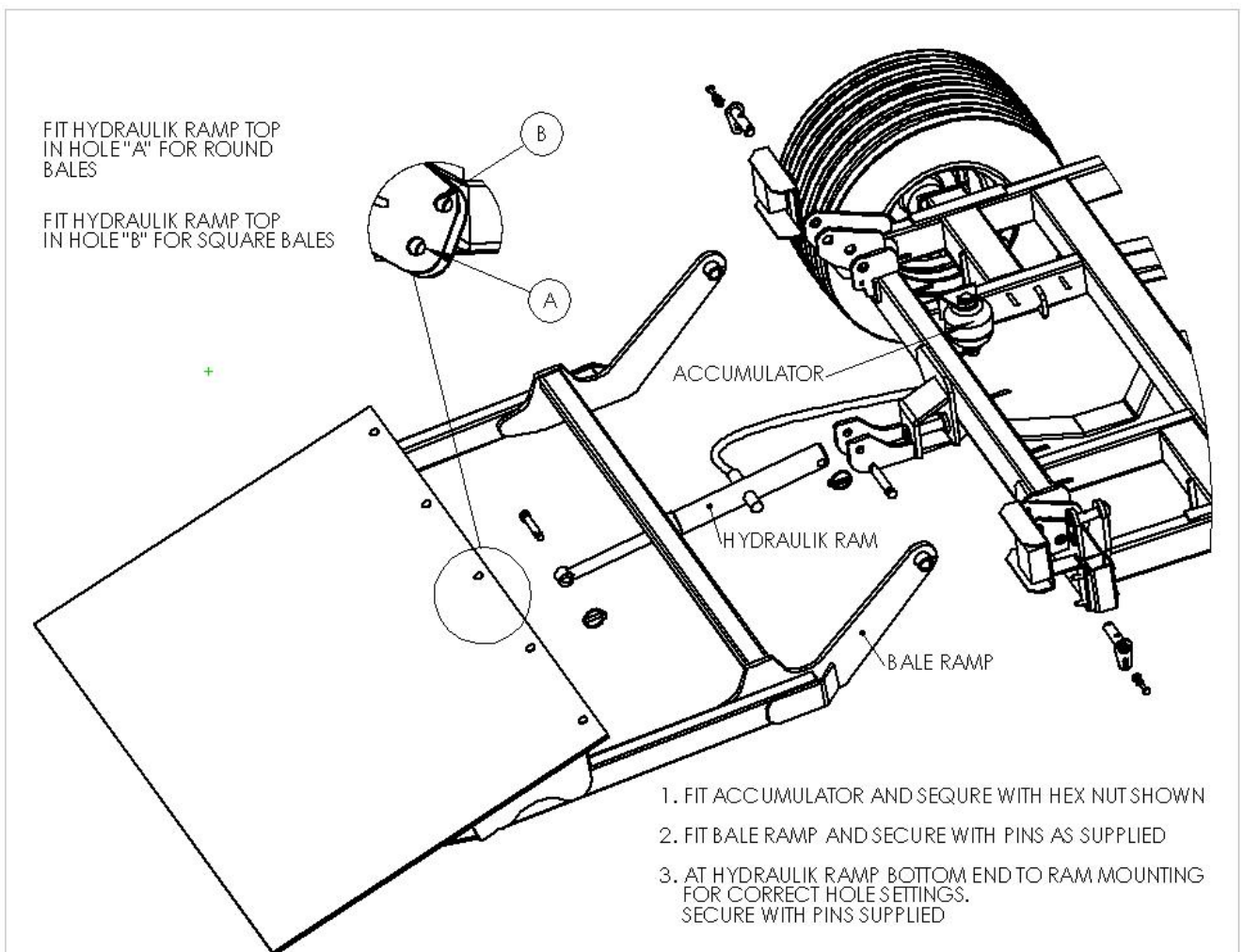

TANCO AUTOWRAP 280S/280ARC/580S/580A
PRE-DELIVERY ASSEMBLY INSTRUCTIONS
END ROLLER, TOP ROLLER & CUT & START UNIT

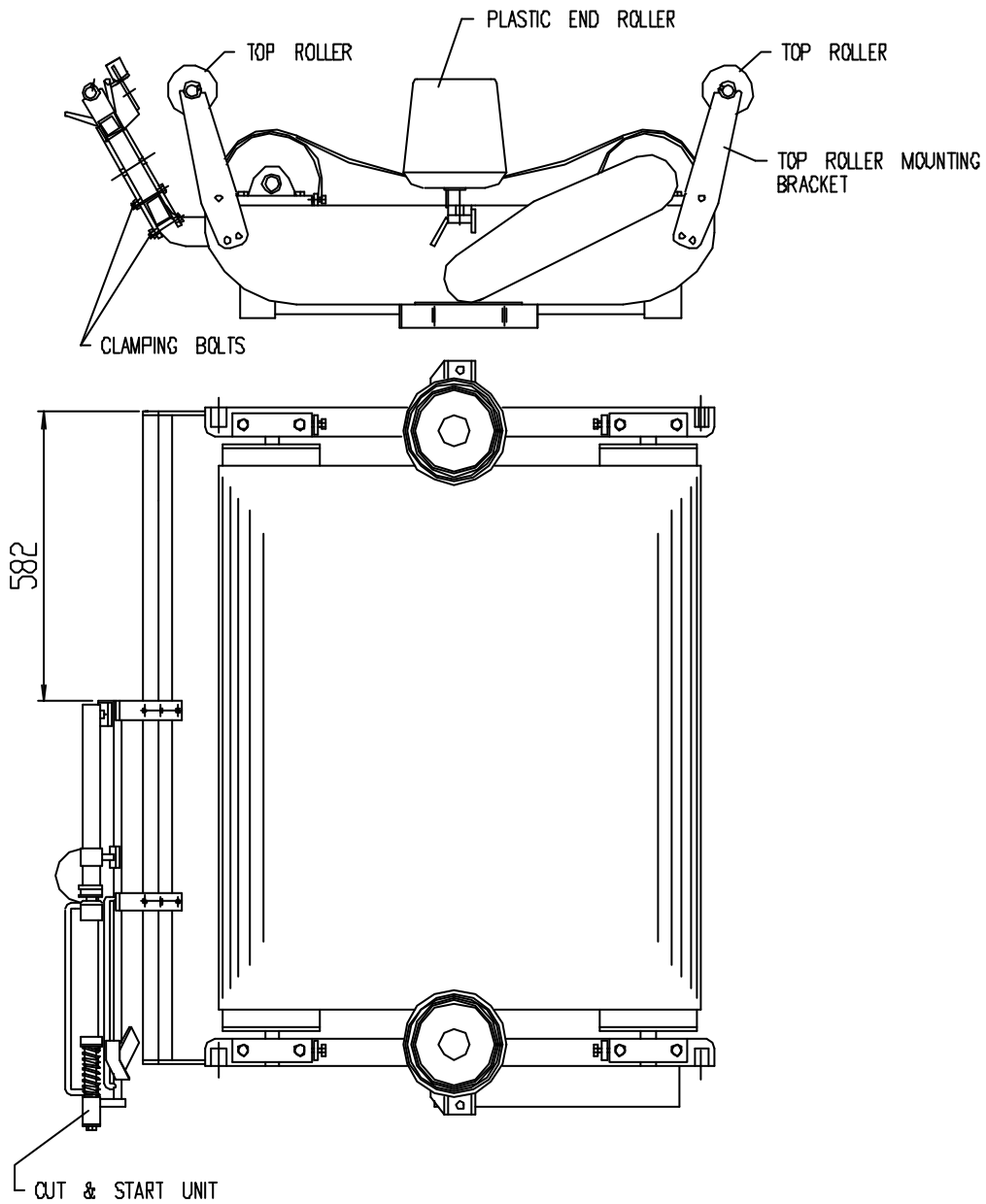

FILE NAME · WD 95 ASS 1

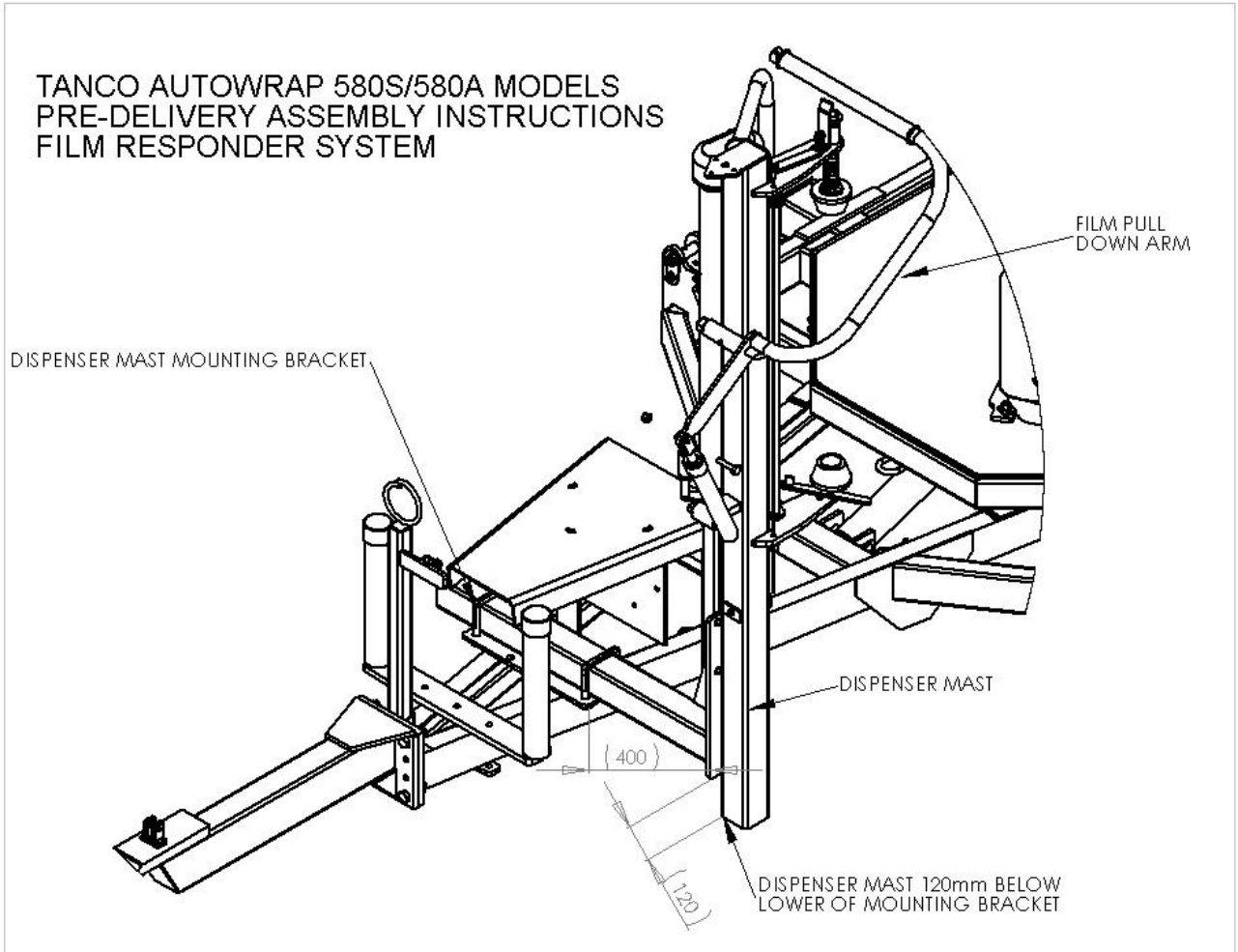



Tanco Autowrap 580-A
Operator's manual

TANCO AUTOWRAP TRAILED MODELS
PRE-DELIVERY ASSEMBLY INSTRUCTIONS
FILM TRANSPORT BRACKET

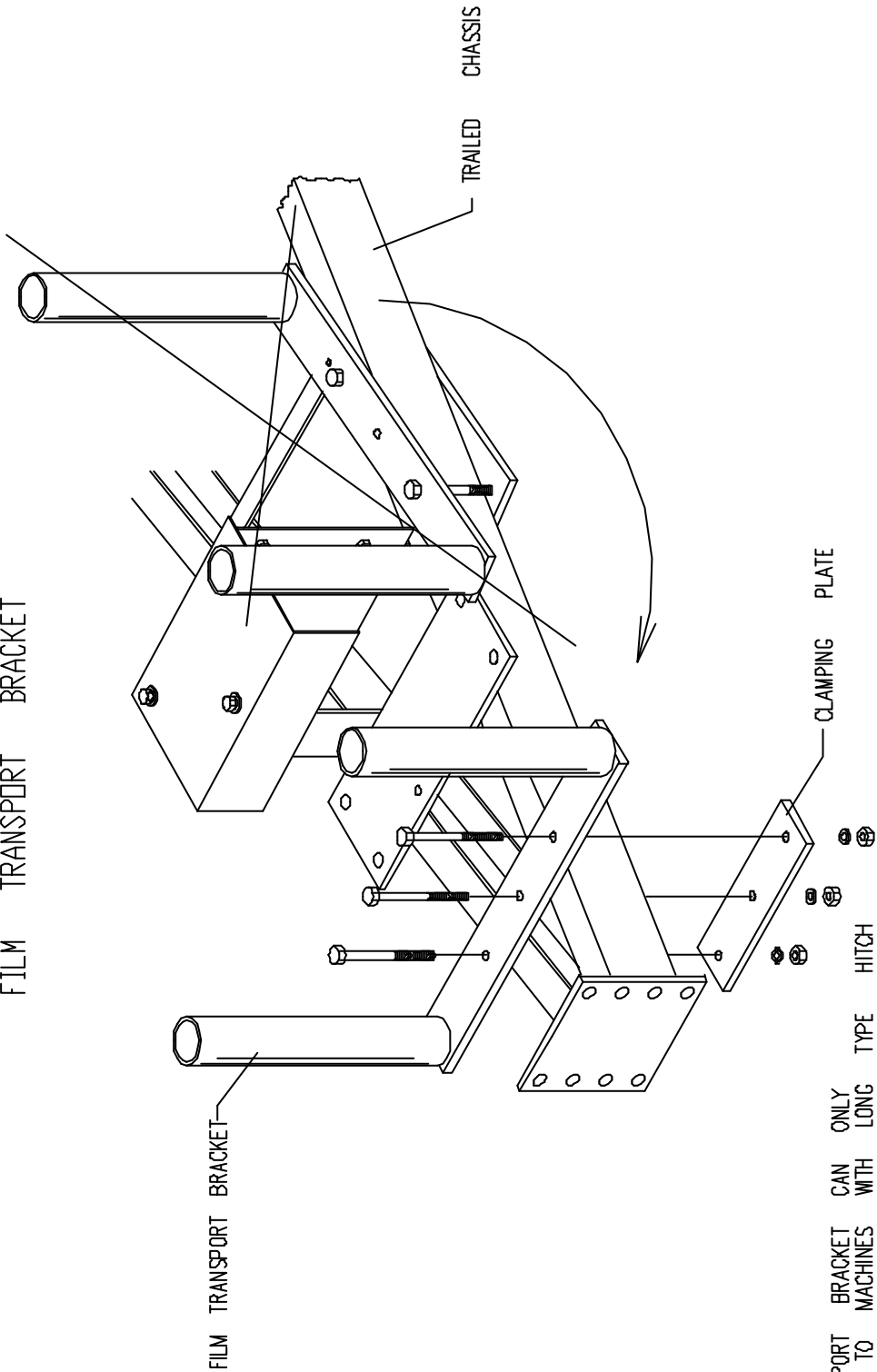

NOTE:
FILM TRANSPORT BRACKET CAN ONLY BE FITTED TO MACHINES WITH WD610-CHL, WD65-HIT, WD610-HHA.

FILE NAME : WD 60 FTBF



2. Operational test

When all above assembly and checks have been carried out, the operation of the machine should be checked as follows:

NOTE: IF YOU ARE NOT TOTALLY FAMILIAR WITH THE OPERATION OF THE TANCO CONTROL SYSTEM, READ THIS MANUAL IN FULL BEFORE PROCEEDING WITH OPERATIONAL TEST.

1. Attach machine to tractor
2. Connect hydraulic hoses to D/A service on tractor.
3. Fit controller box inside cap.
4. Connect control box to the machine and connect power cable direct to the tractor battery. It is important that the leads are connected with the correct polarity.
5. Fit cable control actuator socket to convenient position in cab and locate actuators in socket
6. Lock hydraulic lever in tractor so that oil is flowing through system
7. Check function by operating control levers.
 - (a) Lift arm up and lift arm down. NOTE: Ensure lift arm is down before moving to (b)
 - (b) Turntable rotation forward and reserve.
 - (c) Tip up and down checking hoses are okay.

3. Customer checks

Before despatching consult customer on the following points:

1. That machine model suits his requirements.
2. If the machine is to be operated on a tractor with a closed centre hydraulic system then a closed centre valve is required, see separate instructions.
3. That the tow hitch type is compatible with the tractor. Three different hitch types are available.



4. Transport Instruction

1. Never use straps around machine when lifting. Use only the following lifting points: - Tow hitch and two sockets on each side of Chassis at rear for trailed models. 3 pt. Linkage frame and two sockets on each side of Chassis at rear for 3 pt. Linkage Model.
2. When the machine is towed on the road the lifting arm (if fitted) must be in fully raised position, the safety prop fitted and the axle returned to narrowest position.
3. Raise the Parking Jack on trailed models before moving machine.

5. Machine Identification

The Serial Number plate is located on Chassis forward of offside wheel on trailed models and on 3pt. Linkage frame for 3pt. Linkage model.

Always refer to this number when ordering parts. The Spare parts catalogue number and description should be used. The reference numbers are used to help identifying the spare part.

For your records write serial number here.

SERIAL NO.

6. Preparation of a new machine

1. Check height of film mast to ensure that centre line of film spool is level with the centre line of the bale on the turntable. This will alter with different bale diameters. If this alignment is not correct some adjustment may be required. See fig 1.
2. When connecting to John Deere* tractor the valve must be converted to closed centre. (see p.)

Hydraulic connections

Connect the feed and return hoses from the Autowrap valve to the tractors double acting facility.

NOTE: The return hose is fitted with a non-return valve to protect the Autowrap from damage in the event of incorrect connecting to the tractor hydraulics.

NOTE: To ensure the maximum efficiency and length of lift of hydraulics components this machine requires a clean supply of hydraulic oil.

IT IS RECOMMENDED THAT THE TRACTOR HYDRAULIC FILTER ELEMENT TO BE REPLACED AND THERE AFTER MAINTENANED IN ACCORDANCE WITH THE MANUFACTURES RECOMMENDATIONS.

7. Electrical Circuit Diagram 580-A

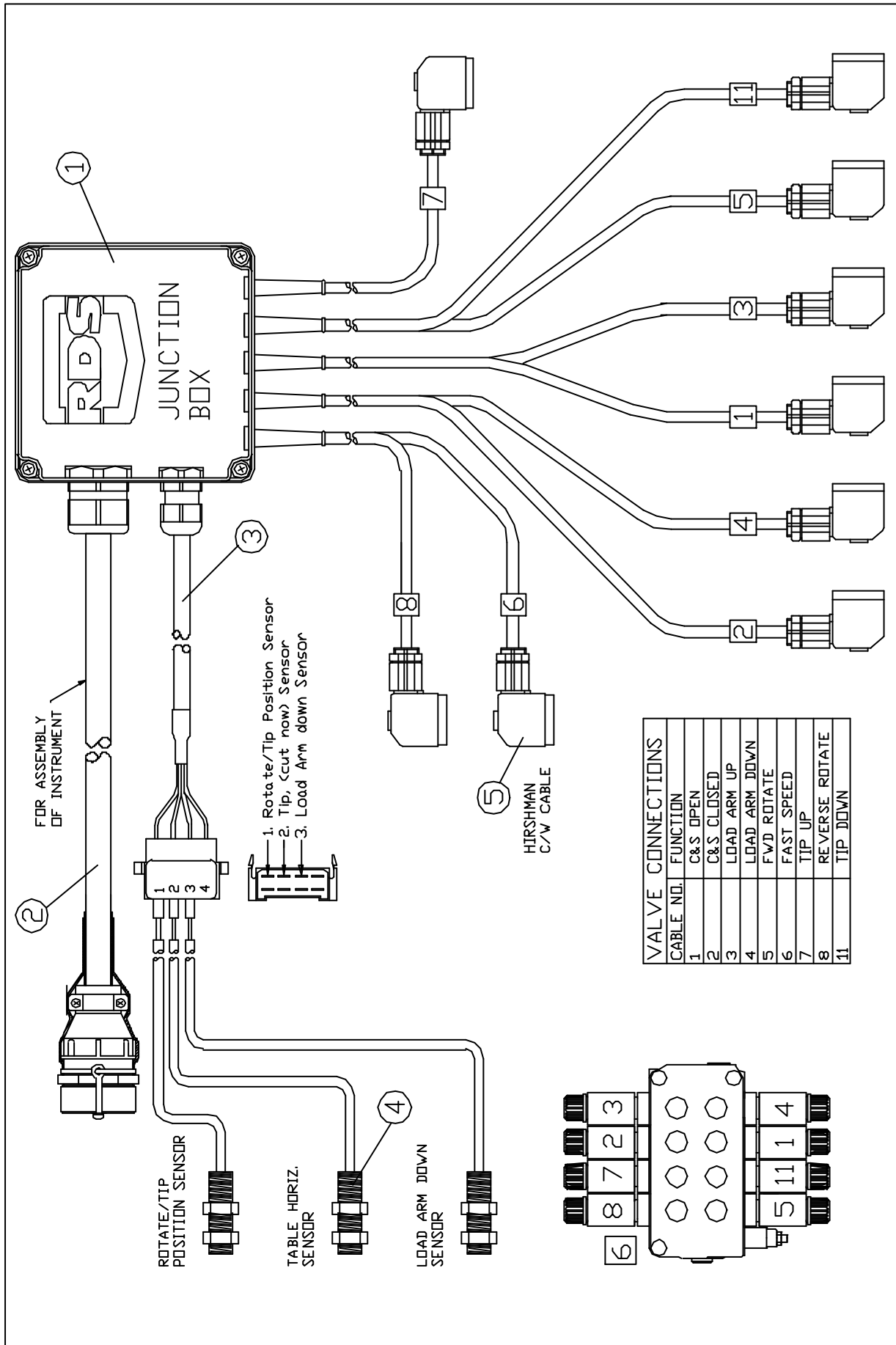



8. Controller Manual 580-A

Contents

1. INTRODUCTION

- 1.1 IMPORTANT SAFETY INFORMATION!
- 1.2 Main operating Functions and Display

2. OPERATION

- 2.1 Operation in Automatic mode
- 2.2 Operation in Manual mode
- 2.3 Manual options in Automatic mode
- 2.4 Operations in Manual mode
- 2.5 The Display Menu
- 2.6 Selecting a Store Total
- 2.7 Resetting a Store Total to Zero
- 2.8 Setting the Number of Wraps
- 2.9 Film Break Alarm (Optional)

3 OPERATOR SETUP MENU



1. Introduction

The Tanco Autowrap Bale Wrap Controller enables the operator to monitor and control the operation of the bale wrapper at any stage of the wrapping cycle. The controller is designed for models: 280ARC, 404EH, 580A, and 1080A table-type wrappers.

There are 2 main operating modes – Automatic and Manual. The automatic mode permits 'one-touch wrapping' to ease the workload on the operator. In addition to the standard auto-wrap cycle where the bale load arm is operated manually, for the 580A and 1080A wrappers, bale loading and unloading can be incorporated into the standard auto-wrap cycle (the 'AUTOLOAD' option).

The controller is fully programmable to optimise wrapping performance. Bale counts are automatically logged in any one of 10 selectable memory stores, in addition to a grand total memory store.

1.1 IMPORTANT SAFETY INFORMATION!



- Please read and understand the instructions for using this controller before operating the machine.
- This controller is fitted with a pushbutton type On/Off Emergency Stop switch. Always ensure the controller is switched OFF via this switch before attempting any adjustment or maintenance to the machine.
- The machine is fitted with a safety beacon which is automatically activated when a loading, wrapping or tipping operation is initiated via the controller. If the beacon is off, do not assume it is safe to move into the proximity of the machine unless you have confirmed that the controller is switched off and the machine power source is disengaged.
- For safety reasons the 280ARC machine beacon will begin flashing 3 seconds before the automatic cycle commences, after initiating the wrapping cycle via remote control. If the beacon begins flashing when you are in proximity to the machine, then **immediately** stand clear.
- Please follow ALL other safety instructions given in the manufacturers' Operator Handbook for the machine.

1.2 Main operating Functions and Display

The principal instrument features and operating functions are shown in figure 1 below.

Figure

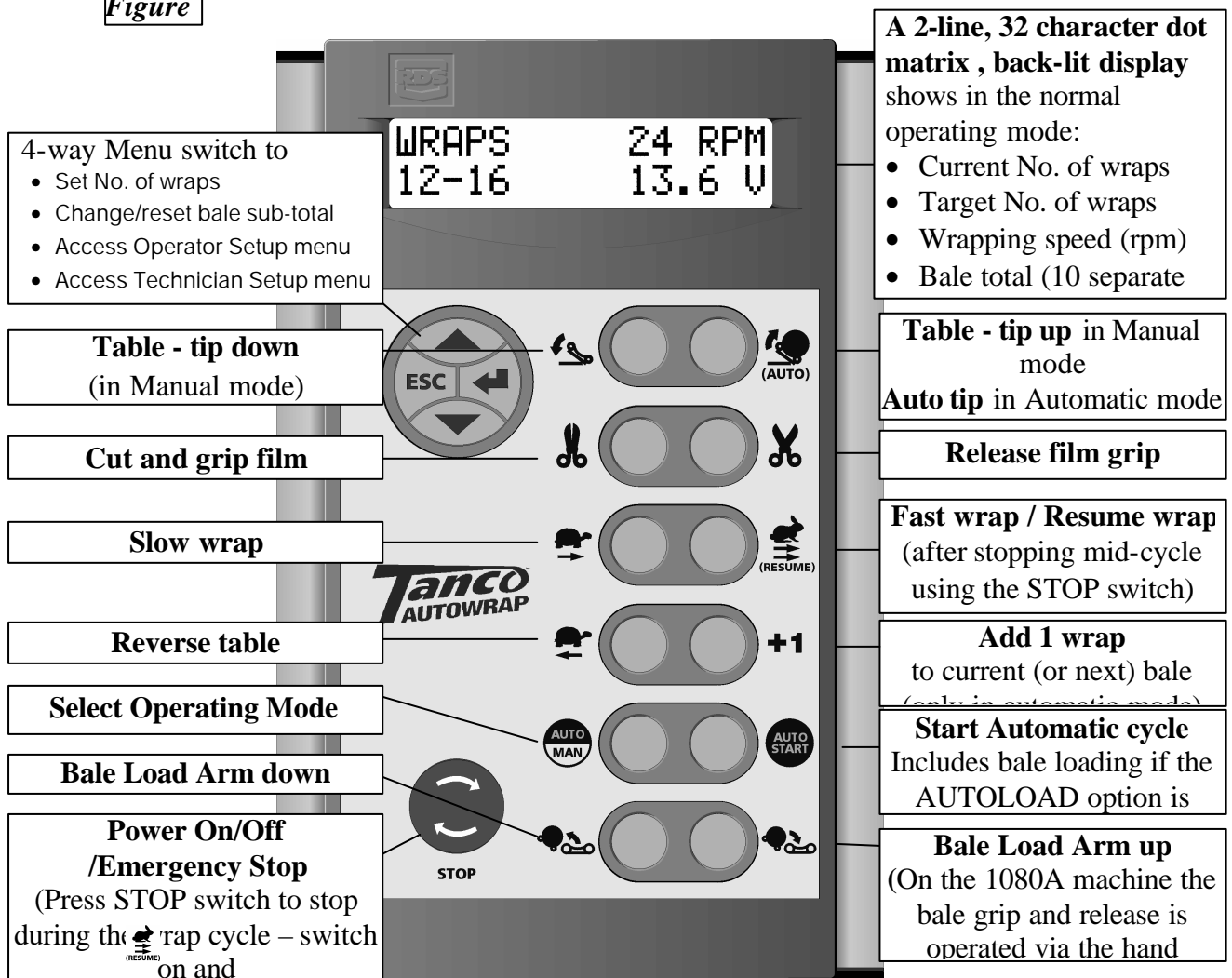

2 Operation

2.1 Operation in Automatic mode

The controller is generally used in automatic mode. With AUTOLOAD set-up (580A / 1080A only), bale loading is incorporated into the automatic cycle for complete 'one touch wrapping'.

'A' on the display indicates that the controller is set in Automatic mode. If not, press  to select.

AUTOLOAD Sequence

Bring the machine up to the bale and press the  switch to commence the automatic sequence – Load, Wrap and Tip Off.

NOTE: The load arm cannot be operated manually to ready the next bale during the wrapping cycle.



Non-AUTOLOAD Sequence

1. Bring the machine up to the bale, then press and hold the  switch to load the bale.

NOTE: On the 1080A machine, the bale grip and release function is operated via the



buttons on the hand controller.

2. Press and hold the  switch to lower the lift arm.
3. Press the  switch to commence the automatic wrapping cycle. The cycle is completed when the target number of wraps has been reached.
4. Press the  switch to tip the bale off and automatically position the table for loading.

2.2 Manually interrupting an automatic wrapping cycle



Press the STOP switch. Pressing the  switch after switching the controller back on will resume the auto-wrap cycle from where it stopped.

For safety reasons, if it is necessary to work on the machine (e.g. in the event of a film break or the film running out), then it is strongly recommended that you disengage the machine power source.

2.3 Manual options in Automatic mode

With the controller in automatic mode, the following manual functions are possible.



SLOW WRAP (only enabled outside of the wrapping sequence). Press  to resume the normal fast wrap.



REVERSE TABLE (only enabled outside of the wrapping sequence). Press this button to nudge the table backwards to the desired position.



ADD 1 WRAP Each time you press this button an additional wrap will be put on the current bale if the wrapping sequence is in progress, or onto the next bale if the automatic cycle has not yet been started. You can add as many wraps as required.





LOAD UP /LOAD DOWN If the 'Autoload' sequence is not selected (580A /1080A only), then you can engage and pick up the next bale while the current bale is being wrapped.

2.4 Operation in Manual mode

'M' on the display indicates that the controller is set in manual mode. If not, press to select.

In manual mode you have total control of every stage of the wrapping cycle.

The software logic determines which manual functions can be activated at any point in the wrapping cycle.

Should the operator incorrectly select a function at a certain stage during the wrapping cycle, then that operation will not be performed.

2.5 The Display Menu

The Display menu is divided into 3 sections. At the top level are the settings used during the daily work with the machine – i.e. Store totals and No. of Wraps.

The Operator Setup' section enables the operator to perform adjustments to the machine operation – e.g. time duration and time delay settings during the automatic cycle.

The 'Technician Setup' menu is not normally accessible to the operator without a PIN access code.

'Technician Set-up' is not covered by this manual.

Use the 4-way switch to navigate the menu. Each menu screen indicates which keys to press to make the settings. The instrument will default back to the main operating display after 30 seconds if no other key is pressed

Here is a summary of the display menu;

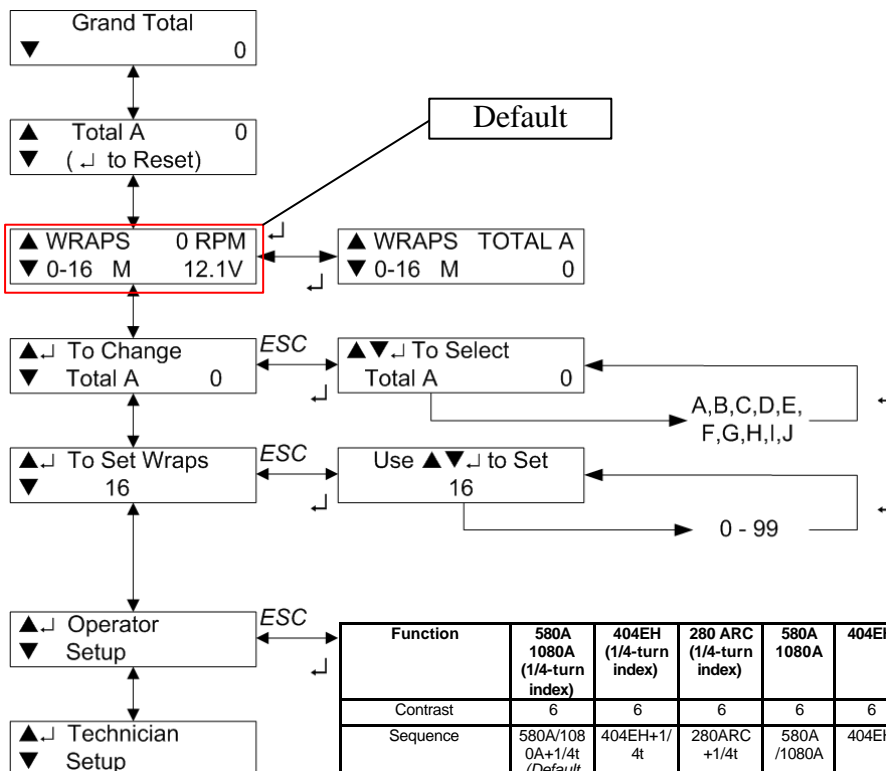

| Function | 580A 1080A (1/4-turn index) | 404EH (1/4-turn index) | 280 ARC (1/4-turn index) | 580A 1080A | 404EH | 280 ARC | 580A AUTO LOAD | 1080A AUTO LOAD | Range | Res. |
|--------------------------------|--------------------------------------|------------------------------|--------------------------------|---------------|---------|------------|----------------------|-----------------------|--------------|------|
| Contrast | 6 | 6 | 6 | 6 | 6 | 6 | 6 | 6 | 0-12 | 1 |
| Sequence | 580A/1080A+1/4t (Default Seq.) | 404EH+1/4t | 280ARC+1/4t | 580A /1080A | 404EH | 280ARC | 580A Auto Load | 1080A Auto Load | | |
| Film Break | OFF | OFF | OFF | OFF | OFF | OFF | OFF | OFF | ON/OFF | |
| Cl Ctr Hyd | OFF | OFF | OFF | OFF | OFF | OFF | OFF | OFF | OC/CC | |
| Squeeze In Duration | 0.0 | 0.0 | 0.0 | 0.0 | 0.0 | 0.0 | 0.0 | 2.0 | 0-9.9s | 0.1s |
| Load Up Duration | 0.0 | 0.0 | 0.0 | 0.0 | 0.0 | 0.0 | 5.0 | 5.0 | 0-9.9s | 0.1s |
| Squeeze Out Duration | 0.0 | 0.0 | 0.0 | 0.0 | 0.0 | 0.0 | 0.0 | 3.0 | 0-9.9s | 0.1s |
| Load Down Pause | 0.0 | 0.0 | 0.0 | 0.0 | 0.0 | 0.0 | 0.0 | 3.0 | 0-9.9s | 0.1s |
| Tip Up Duration | 4.0 | 4.0 | 4.0 | 4.0 | 4.0 | 4.0 | 4.0 | 4.0 | 0-9.9s | 0.1s |
| Tip Up to Tip Down Delay | 0.3 | 0.3 | 0.3 | 0.3 | 0.3 | 0.3 | 0.3 | 0.3 | 0-9.9s | 0.1s |
| Tip Down Duration | 4.8 | 4.8 | 4.8 | 4.8 | 4.8 | 4.8 | 4.8 | 4.8 | 0-9.9s | 0.1s |
| Delay before Slow Stop | 1.2 | 1.2 | 1.2 | 1.2 | 1.2 | 1.2 | 1.2 | 1.2 | 0-9.9s | 0.1s |
| Delay to stop after last pulse | 23.0 | 0.0 | 0.0 | 0.0 | 0.0 | 0.0 | 0.0 | 0.0 | 0-9.9s | 0.1s |
| Language | English | English | English | English | English | English | English | English | E/F/D/N L/DK | |



NOTE: There are additional sequences selectable in the Operator Setup menu but not shown in the table. These sequences are for wrapper models to which this manual does not apply. Please refer to section 3 for further explanation of the Operator Setup functions given in the table above.

2.6 Selecting a Store Total

There are 10 individual memory registers labelled 'Store A' to 'Store J' for bale totals. Each time a bale cycle is completed, the currently selected store total and the grand total increments by 1.

The currently selected store is displayed on one of the two screens selectable in the normal operating mode.

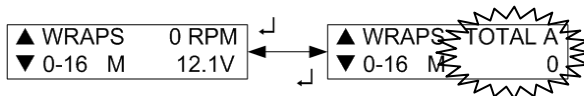

The default setting is Store A. To select a particular store, navigate the display menu using the 4-way switch.

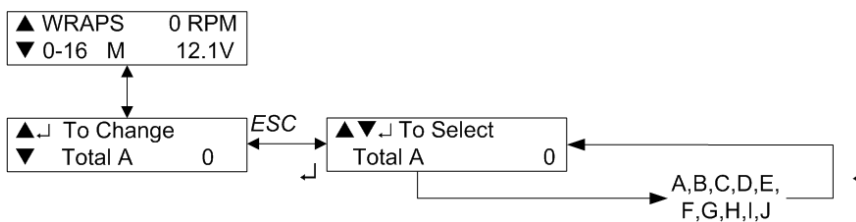

Press the up/down arrow keys to select the store, then press the ENTER key to confirm the selection.

2.7 Resetting a Store Total to Zero

Stores A to J can be individually reset to zero at any time. The Grand Total store cannot be reset. First select the store to be zeroed, then navigate the display menu as shown below.

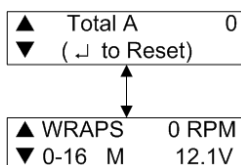

Press the ENTER key to reset.



2.8 Setting the Number of Wraps

The default number of wraps is 16. You can set the target number from 0 to 99 by navigating the display menu as shown below.

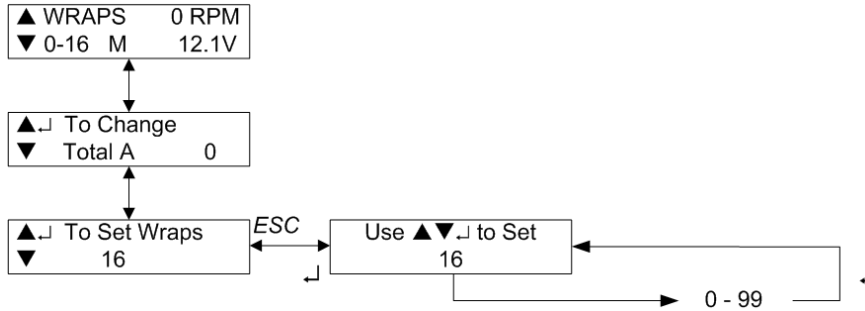

2.9 Film Break Alarm (Optional)

If the film breaks or runs out during the wrapping cycle, the instrument will sound an audible alarm and the display will show **FILM BREAK**.

Wrapping will stop at this point. Press  when you are ready to resume the auto-wrap cycle.



3 Operator Setup Menu

The default settings for the machine are developed by Tanco for optimal operation of the machine. However, the operator can change certain parameters in the 'Operator Setup' menu to take account of operational conditions.

| Parameter | Default | Application | Description |
|----------------------|--------------|--|---|
| 'Film Break' | OFF | N/A | N/A |
| 'CL CTR HYD' | OFF | All | Closed Centre Hydraulic Valve operation: 'OFF' – System pressure valve dumps to tank when no function is operating (for tractors with fixed-output hydraulic system). 'ON' – System pressure valve stays energised (for tractors with demand-sensing hydraulic system). |
| 'Squeeze IN' | 2.0s | 1510S,1514S, 1514T only | The time period required for the gripper arm to grip the bale sufficiently. Increase setting if the bale grip is insufficient. |
| 'Load UP' | 5.0s | 580A AUTOLOAD 1080A AUTOLOAD | The time period required for the load arm to reach the point at which the bale transfers onto the table. Adjustment may be required to set the optimum stopping point. If bale transfer is inconsistent, then increase setting to raise the stopping point |
| 'Squeeze OUT' | 3.0s | 1080A AUTOLOAD only | The time period required for the gripper arm to release the bale. Increase setting if the bale gripper arm does not extend sufficiently. |
| 'Load DOWN Pause' | 0.0s 3.0s | All except 1080 AUTOLOAD 1080A AUTOLOAD | The pause duration after the load arm reaches its uppermost position, to allow for the bale to transfer onto the table rollers. Adjustment may be required depending on the size/type of bale. Increase setting if the bale does not transfer in sufficient time. |
| 'Tip UP' | 4.0s | All | The time period required for the table to reach the tip off position and offload the bale. Increase setting if the table does not tip far enough. |
| 'Tip Up to DOWN' | 0.3s | All | The pause duration after the table has tipped up, to allow for the bale to roll off. |
| 'Tip Down' | 4.8s | All | The time period required for the table to return to the horizontal position. Increase setting if the table does not fully return onto the supporting base |
| 'Slow Stop Wait' | 1.2s | All | Set the point at which the table slows down towards the end of the wrapping cycle. Adjustment may be required depending on the weight of the bale. Decrease setting if the table overshoots the Stop position. |
| 'Delay to Stop' | 0.0s | All | Set to adjust the table Stop position. |
| Language | English | All | Sets the language for the display prompts. |

9. MODE OF OPERATION 580-A

- Fitting roll of film.

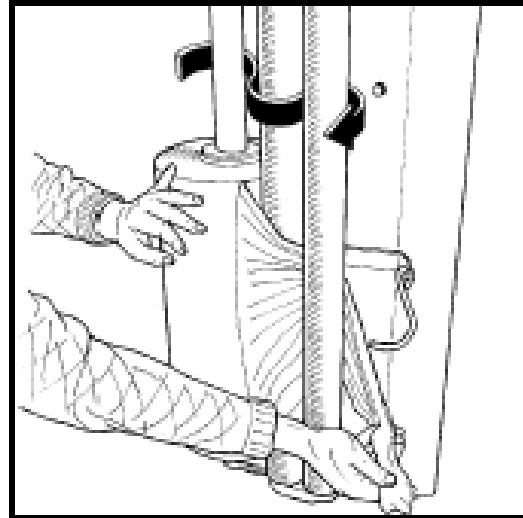
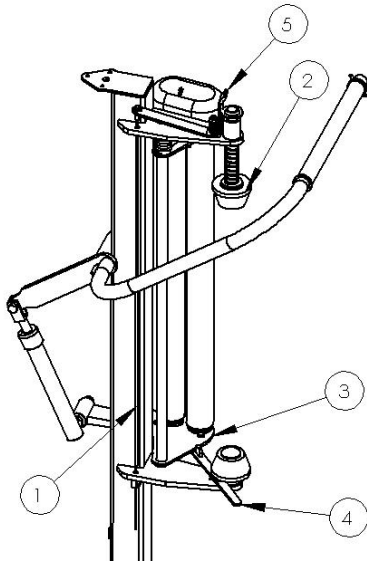

Fig. 5-2

- When loading a plastic roll, first ensure the top cone (2) is pushed up to latched position, then push back the Stretch rollers (3) until held in position by locking catch (4).
- Place the Roll on the Bottom Cone and release the top latch (5) by pushing the wire cord (1).
- Pull the film between the rollers on the pre-stretcher in the direction of the arrow. (See fig. 5-2). (See also the sticker on the dispenser).

AUTOMATIC MODE:

1. Ensure turntable is in correct position to accept bale and that film is gripped by "Cut and Start".
2. Lower bale lift arm, drive alongside, pick up the bale and raise the left arm.
3. Allow the bale to roll gently onto the turntable so that it is central between the end rollers.
4. Lower the arm clear of the turntable and press the "Auto" button commence wrapping. NOTE: The table must be in the correct position before the "Auto" button is pressed.
5. With the controller in Automatic mode the turntable will start off for half of one rotation in "Slow Mode" before changing to "Fast Mode". During the final rotation it will change to "Slow Mode" and stop in the correct position so that the film is lined up above the open "Cut and Start". NOTE: The turntable can be moved to left or right to align the "Cut and Start" by using the Forward/Reverse rotate switch on the controller or the buttons on the remote control unit.
6. On the third rotation of the wrap cycle the "Cut and Start" will open automatically.
7. When in a safe position to do so, press the "Tip Up" button, the turntable will tip upwards gathering the film on the "Cut and Start" plunger whilst the pull down arm reduces the film to a rope which is cut as the "Cut and Start" closes, cutting the film and gripping the film end in readiness for the next bale.
8. The tip off sequence is automatic and once the turntable lowers it will rotate forward and stop in position to facilitate loading, if programmed to do so.



Warning Lift Arm

The Lift Arm on the trailed machine is designed to pick up and deposit bales onto the turntable prior to wrapping and to raise the machine while empty, to facilitate adjustment to sliding axle. It is not intended to be used for transporting bales over distances or for use as stabiliser whilst wrapping.

Therefore, any use of the lift arm outside its primary function will be deemed to be abuse and will void all warranty.

TANCO DUAL STRETCH FILM DISPENSER

Some Tanco Autowrap machines can optionally be fitted with a patented dual stretch gear system.

This system enables a quick change of stretch levels on the Film Dispenser.

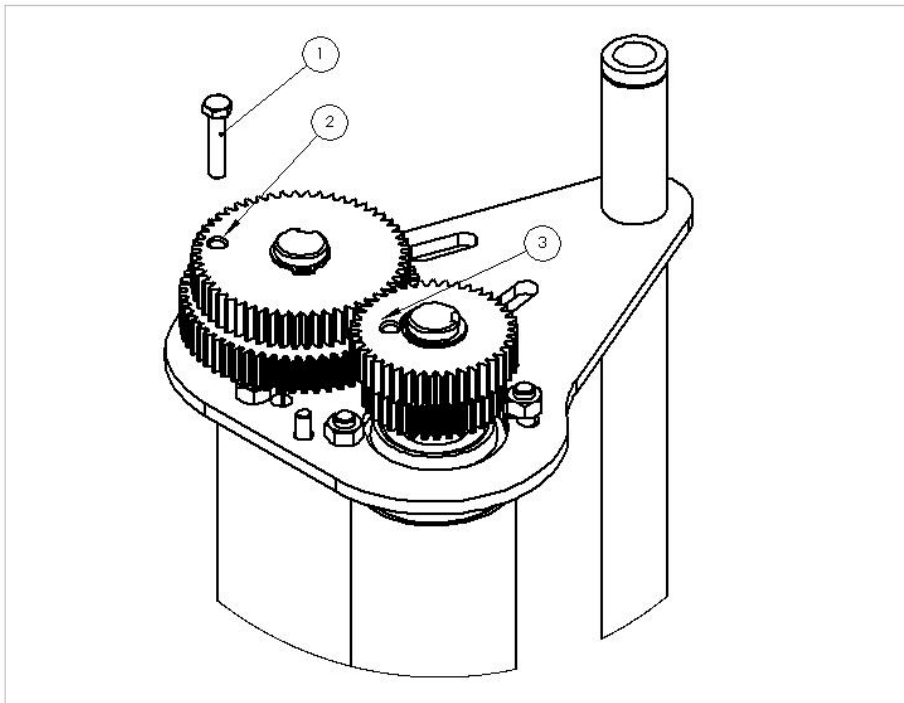

If the bolt (1) is fitted in position 2, the top set of gears provide the stretch (70%).

By removing the bolt from position 2 and fitting it in position 3, the bottom set of gears become the stretch gears giving 32% (for prestretched film) or optionally 55% (for use in hotter climates or with square bales).

Tanco Dispenser Gear Combinations

| Inner Gear | Outer Gear | % Stretch |
|------------|------------|-----------|
| 60 Tooth | 35 Tooth | 70% |
| 58 Tooth | 37 Tooth | 55% |
| 54 Tooth | 41 Tooth | 32% |



11. Film, Overlap System

The Autowrap is fitted as standard with the 2 x 2 x 50% film overlap system. This is achieved by means of a chain drive which ensure that the correct number of film layers are applied to the bale after a specific number of revolutions of the turntable. The number of revolutions required to wrap a bale depends on width of film being used and bale size – See Table 1 below. The chain to be positioned on inner sprockets for 750mm wide film (Factory set-up). See below.

For use with 500 mm film, the chain must be fitted to the outer sprockets. For 500mm film an optional film adaptor is required to fitting film in Dispenser. See parts Book.

For silage bales we recommend the application of a minimum of four layers of film.

Table 1

| Bale size | Width of Film Roll | Bale Indicator Setting (Revs) |
|---------------|--------------------|-------------------------------|
| 120cm x 120cm | 750mm | 17 |
| 120cm x 137cm | 750mm | 19 |
| 120cm x 150cm | 750mm | 21 |

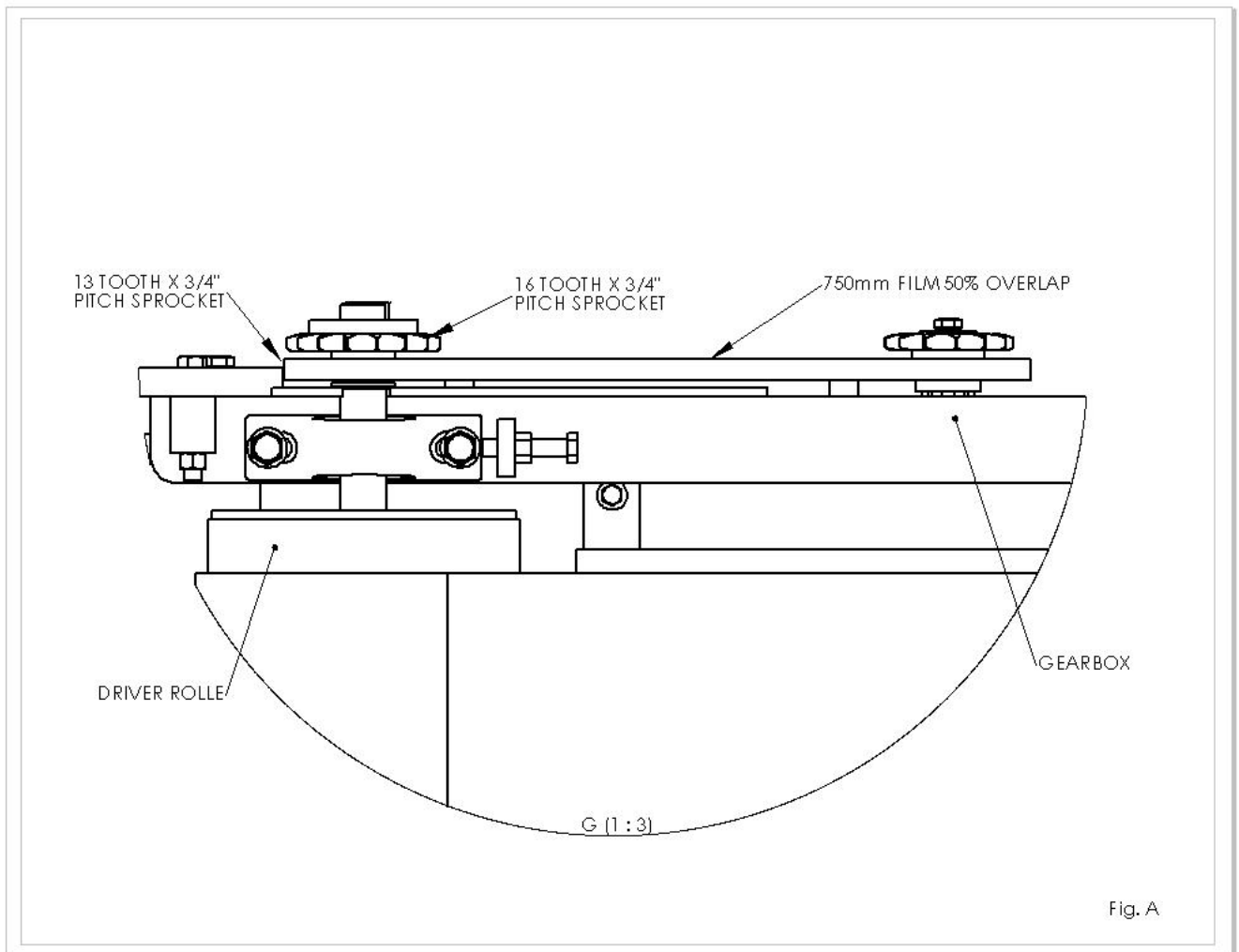

Important

The above recommendations are only offered as a guide to correct wrapping of silage bales and the manufactures accept no responsibility for variations that many arise and the consequence of same. They are based upon turntable speeds of up to 25 r.p.m., and a approx film width of 600mm applied to end bale when using 750mm wide film roll.

It is the responsibility of the operator to ensure the correct number of wraps are applied, as variances can occur with fluctuations in speed of rotation, film quality and tensioning, shape and density of bale etc.



12. Service and Maintenance

1. All nuts and bolts should be tightened after one hour's use, thereafter regularly.
2. Wheel pressure should be normally kept at 42 psi depending on bale weight and field conditions.
3. Inspection moving parts for wear on daily basis.
4. Lubrication

| | |
|------------------------------|---|
| Drive chain & sprocket | Grease every 24 hours |
| Main rollers | Grease every 24 hours |
| Hinge pins on lift | Grease every 24 hours |
| Hinge pins on main tip frame | Grease every 24 hours |
| Hydraulic rams | Grease every 24 hours |
| Film spool assy | Grease every 24 hours |
| Dispenser gearboxes | One shot of Grease every, 500 bales. See 6 |
| Main spindle | Grease even 4000-5000 bales |
5. Adjustments
 - Turntable drive chain: Adjust after first days work then check/adjust every 50 hours. See Fig. 8
 - Gearbox Drive chain: Adjust after first days work then check/adjust every 50 hours. See Fig. 2
 - Roller Drive chain: Adjust after first days work then check/adjust every 50 hours. See Fig. 3
 - Main Bale Belt: See belt tracking instructions.
6. Film Dispenser

Apply P.T.F.E. based grease to gears every 2 to 3 months.
7. Film Adjustment

Centre of film roll must be in line with centre of bale and the film mast should be vertical.

8. Shear Pins

There are two shear pins fitted to sprocket assembly on drive roller see fig. 5. If the pins shear, remove the broken pins re-align holes and fit two replacement spiral pins, 6mm dia x20mm long, Din 7344. There are two spare shear pins attached to inside of chain guard.

NOTE: If shear pins are replaced with other than specified above all warranty is null and void.

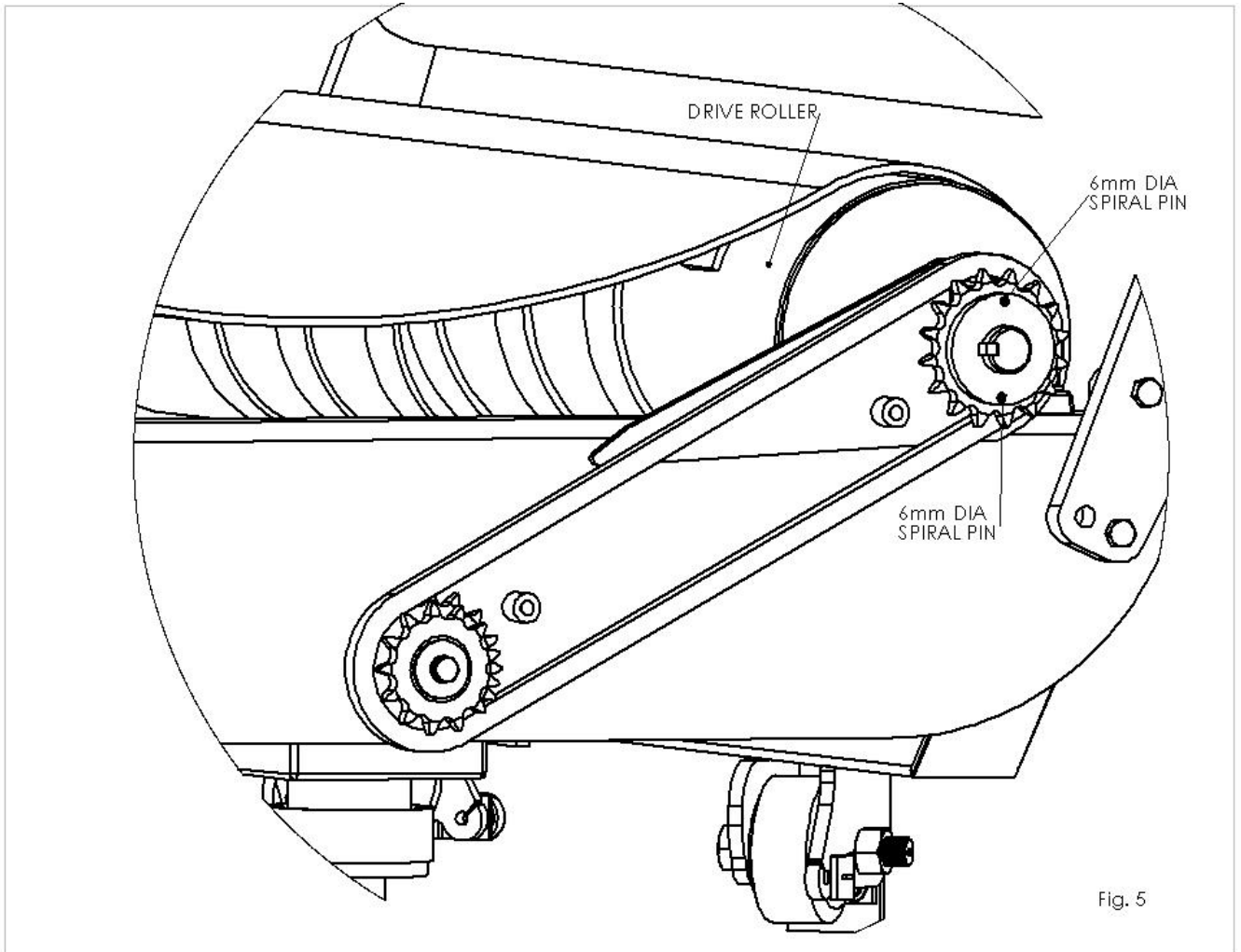

Fig. 5

Service and maintenance (cont.) hydraulic filter

1. Before connecting Autowrap to tractor, check the quality of the oil in the tractor hydraulic system and replace hydraulic filter.
2. After 25 hours max it will be necessary replace the element in Autowrap filter.
3. For maintenance purposes it is necessary to change the element after 200 working hours.
4. The element cannot be just cleaned and put back into the housing.

13. Technical Diagrams

13.1. Film Threading Diagram

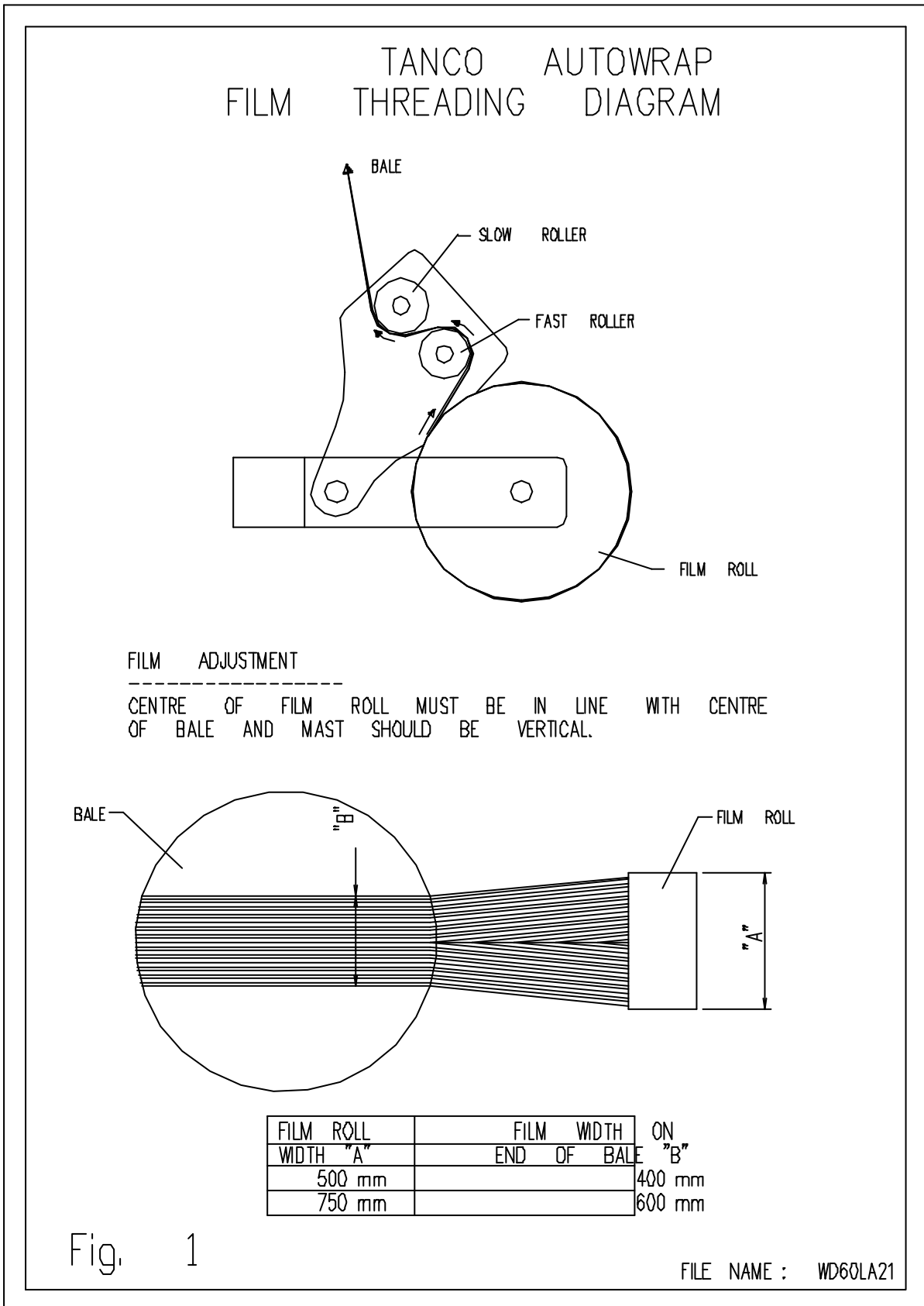

13.2. Gear Box Chain Drive tensioning system

TANCO AUTOWRAP CONSTANT INDEXING

GEARBOX CHAIN DRIVE TENSIONING SYSTEM

- CHAIN TENSIONING PROCEDURE
1. LOOSEN M 10 BOLT SECURING CHAIN TENSIONER.
 2. TENSION CHAIN BY ADJUSTING TENSIONER USING SPANNER IN DIRECTION OF ARROW *X* UNTIL SETTING OF 1.5 - 20 IS REACHED
 3. RE-TIGHTEN M 10 BOLT TO SECURE TENSIONER IN POSITION.

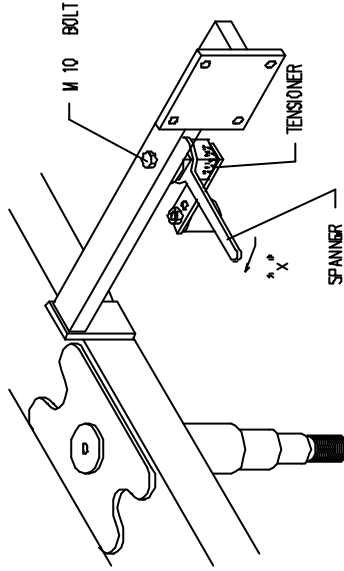
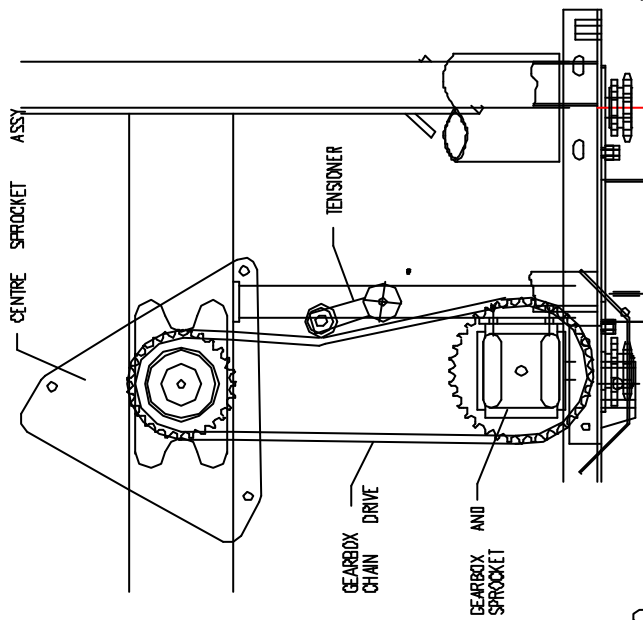

Fig. 2



ROLLER CHAIN DRIVE TENSIONING SYSTEM

- CHAIN TENSIONING PROCEDURE
1. LOOSEN M 14 BOLTS SECURING BEARING
 2. TENSION CHAIN BY LOOSENING LOCKING NUT AND TURNING ADJUSTER BOLT CLOCKWISE TO TAKE UP SLACK IN CHAIN. SECURE IN POSITION WITH LOCKING NUT. ENSURE EQUAL ADJUSTMENTS ARE MADE ON BOTH SIDES.
 3. RE-TIGHTEN M 14 BOLTS SECURING BEARINGS TO 170 Nm (125 FT. lbs.).

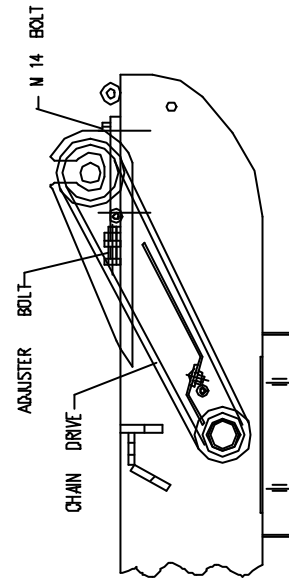

Fig. 3

FILE NAME · WD 80 LA 6

13.3. Turntable Chain Drive tensioning system

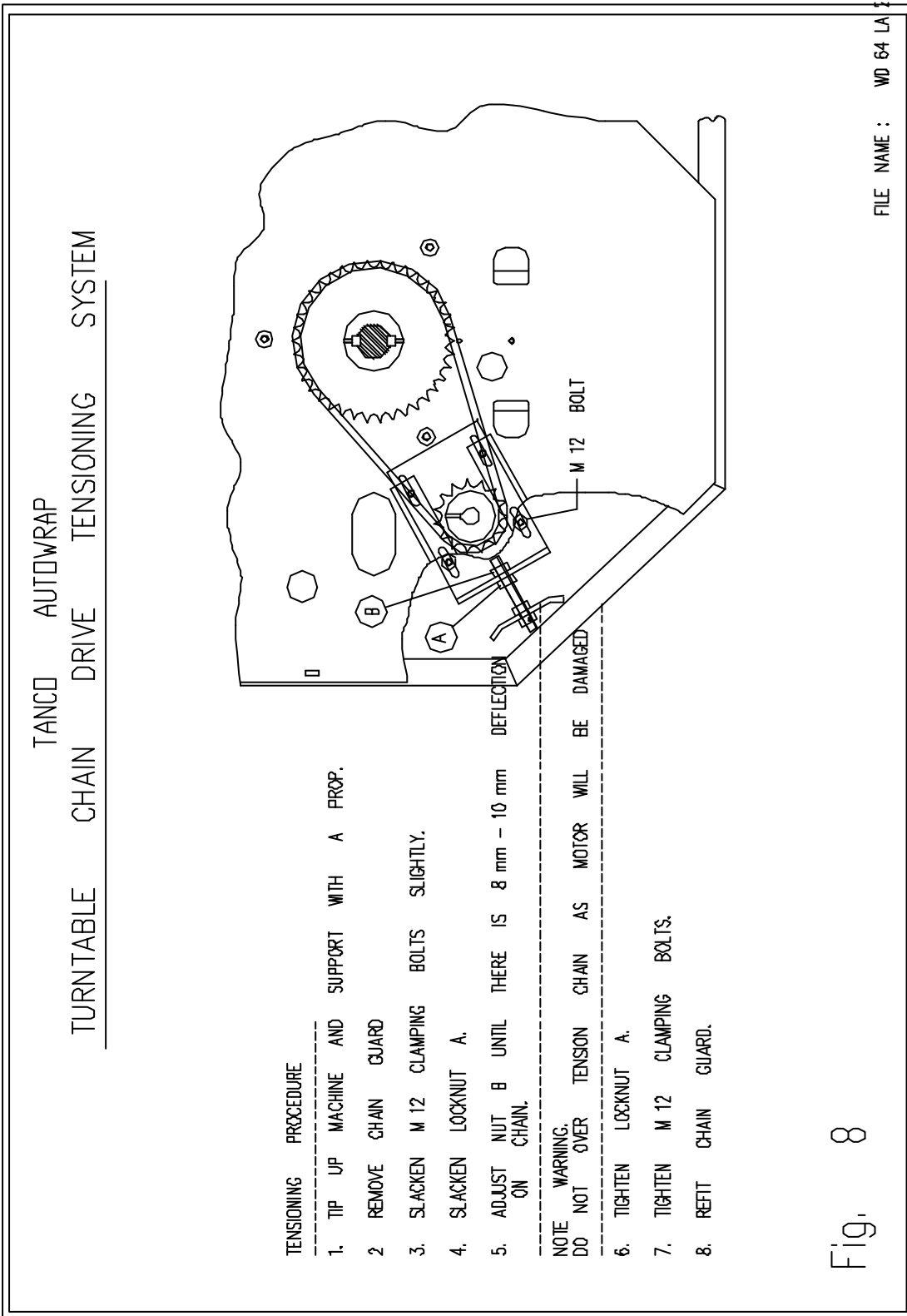
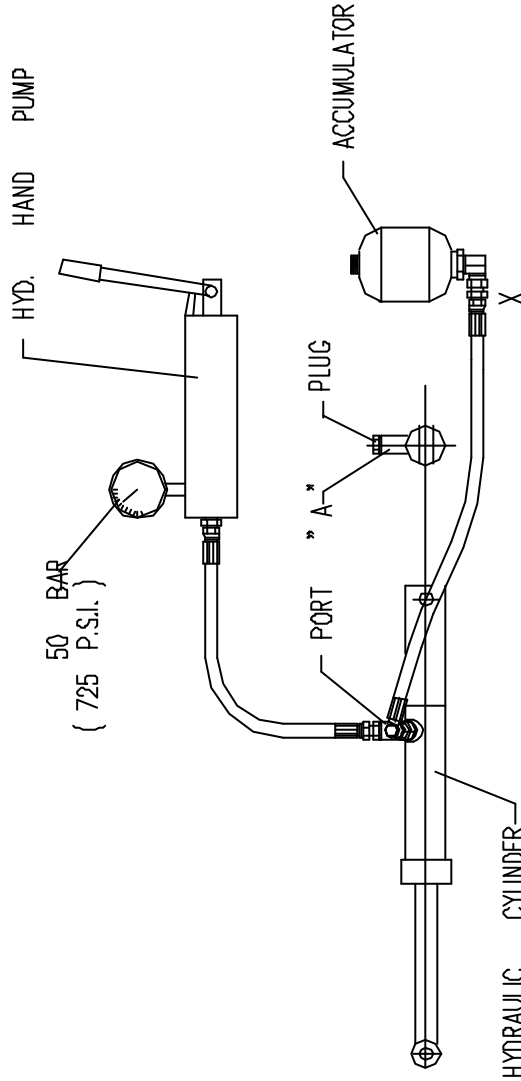

Fig. 8

13.4. Bale Ramp Cylinder - recharging instruction

INSTRUCTIONS FOR RECHARGING AND REDUCING PRESSURE IN HYDRAULIC BALE RAMP CYLINDER



TO RECHARGE CYLINDER

1. REMOVE PLUG FROM PORT "A".
2. CONNECT HOSE FROM HYD. HAND PUMP TO PORT "A" TO ALLOW OIL TO BLEED OUT SLOWLY.
3. CHARGE CYLINDER TO A PRESSURE OF 50 BAR (725 P.S.I.) TIGHTEN CONNECTION AND CHECK OPERATION
4. BLEED AIR FROM SYSTEM BY SLACKENING HOSE CONNECTION OF BALE RAMP .
5. REMOVE PLUG FROM PORT "A" . RETIGHTEN CONNECTION UNTIL OPERATION OF RAMP AT BASE OF ACCUMULATOR MARKED X . RETIGHTEN CONNECTION UNTIL OPERATION OF RAMP

TO REDUCE PRESSURE IN CYLINDER

1. SLACKEN CONNECTION ON HOSE END JUST ENOUGH

FILE NAME : WD 66 PL 2 E

13.5. Cut & Start Cylinder – recharging

TANCO AUTOWRAP - HYDRAULIC CUT AND START
INSTRUCTIONS FOR RECHARGING HYDRAULIC CYLINDER

1. REMOVE PLUG FROM PORT "A" .
2. CONNECT HOSE FROM HYD. HAND PUMP TO PORT "A" .
3. CHARGE CYLINDER TO A PRESSURE OF 60 BAR (870 P.S.I.)
4. REMOVE HOSE FROM PORT "A" AND REFIT PLUG .

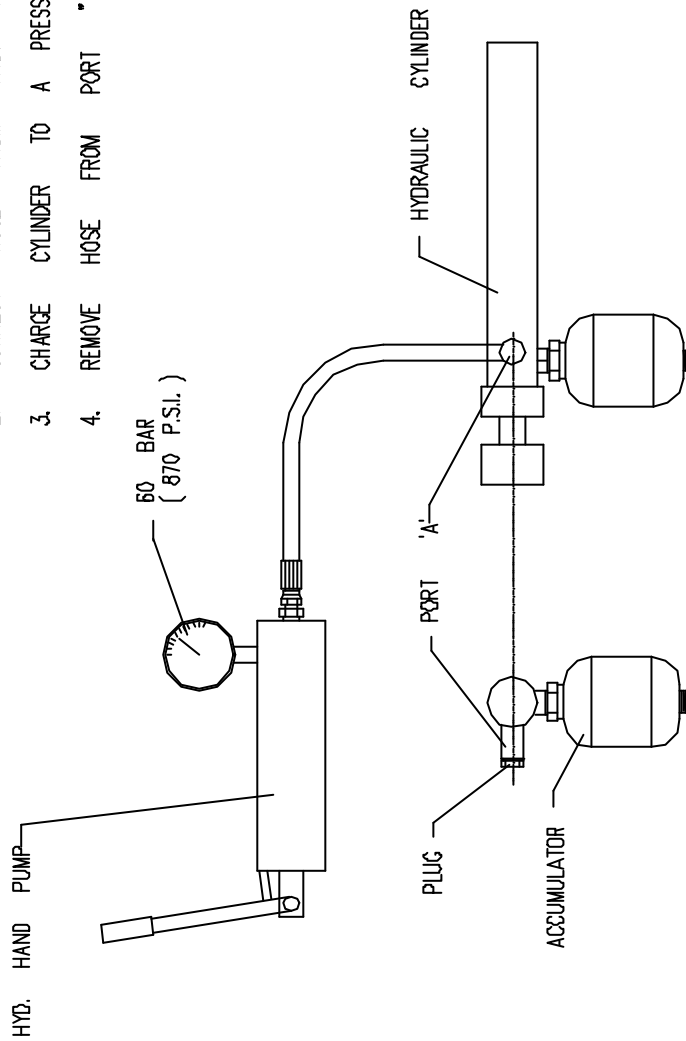

14. Hydraulic Circuit Diagram 580-A

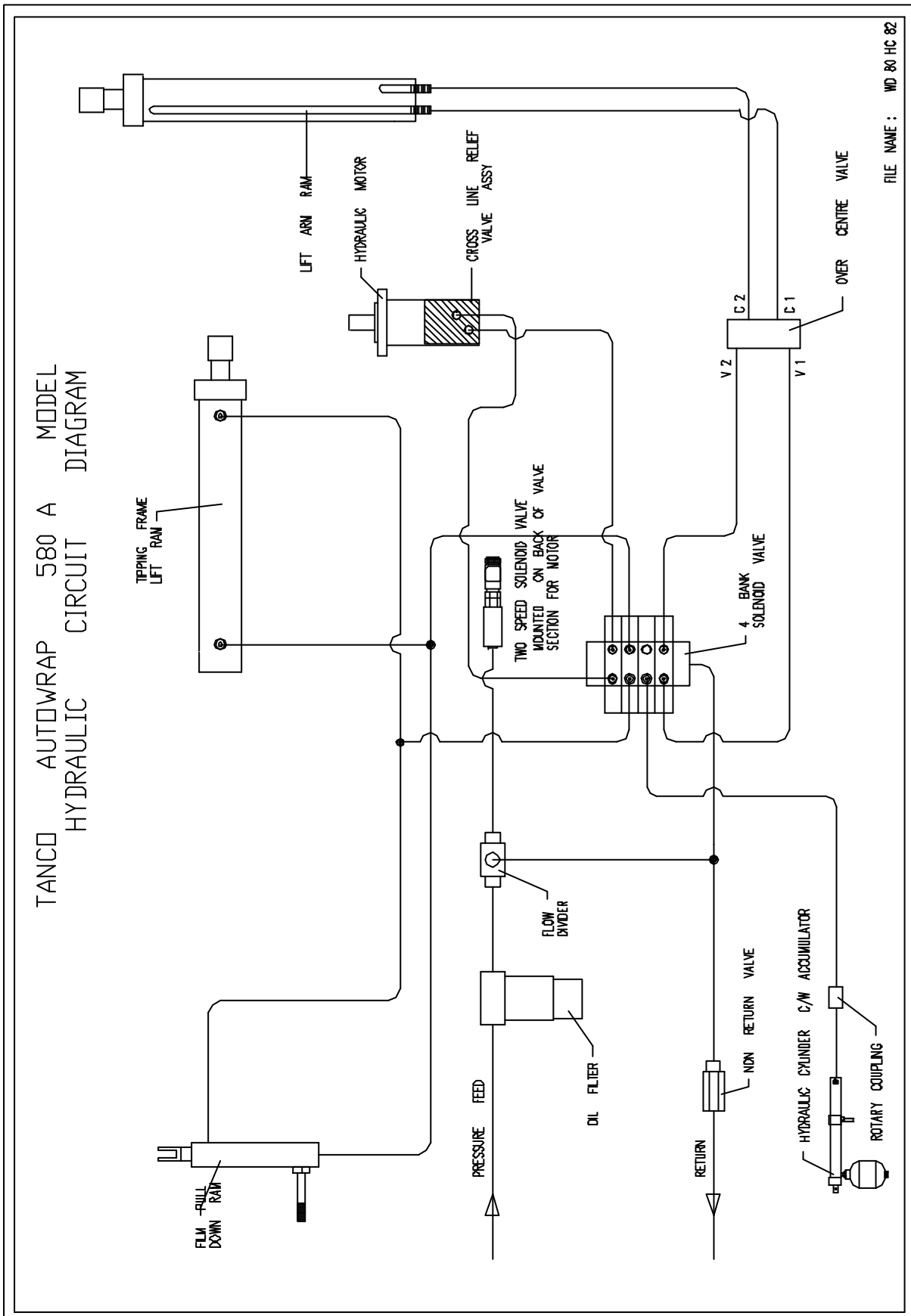



15. Fitting Closed centre Plug.

Most tractors are fitted with Open Centered Hydraulic systems. For this reason, our valves are set-up as standard for open centers. However some tractors (e.g. John Deere) use closed centered systems. Consult your dealer if you are unsure about your system requirements. To convert to closed centers a plug must be changed in the valve block. This plug is located on the valve just beside the outlet (T line). Remove the existing one and replace with closed center plug (Part No. Z01-03-A580J).

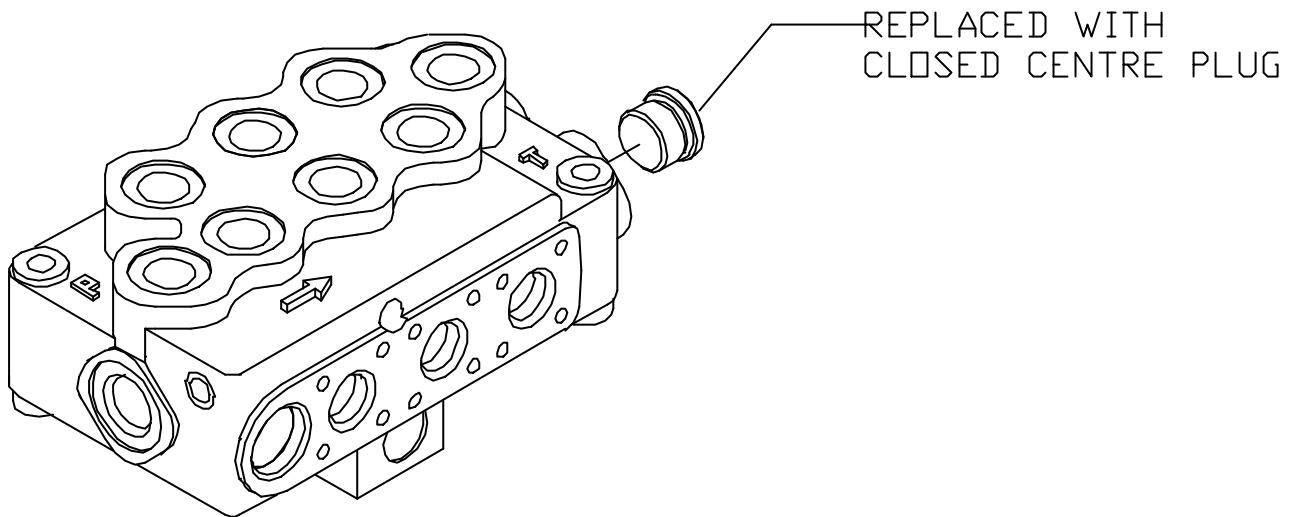

If you are likely to change frequently between open and closed centered hydraulic systems and special plug incorporating a tap can be ordered. (Part No. 1008050- closed center tap plug). This is fitted in the same position on the valve.



16. FAULT FINDING (ROUND BALE MODELS)

PROBLEMS

Driver roller and Bale belt not driving.

Film not wrapping evenly

Film breaking

Hydraulic bale ramp not returning to raised position after tripping off Bale.

Pull down arm will not stay down on film when tipping off Bale.

Hydraulic Cut & Start

Cylinder will not go out all the way.

Cut and Start closed and will not open.

Cut & Start will not close

When tipping up turntable and if it does not stop and cut but Continues Tipping up.

REMEDY

Check if shear pins have sheared in sprocket on drive roller if so, Replace.

Adjust the film mast, so that centre of film roll is in-line with the centre of the Bale

Wash off the dispenser.
Change film roll
Use only recommended film.

Hydraulic cylinder loss of oil pressure, Recharge see instruction Manual.

Restrictor not fitted or dirt under seat of restrictor.

Hydraulic pressures in tractor not high enough (bad pumps) or too much oil pressure in accumulator side of cylinder over 60 bar.

Pressure lost in accumulator side of cylinder, seals leaking across, or oil leak from gland.

Poppet valve open must have more than 4 revolutions of turntable before Cut & Start will close, or dirt under poppet valve

Check wiring and button switch, if all wires check out ok, dirt might be the problem in the six-port diverter valve, if so disassemble and clean out with petrol or gasoline



THIS IS VERY IMPORTANT

Make sure you have a good connection on the battery both positive and negative

BALE MOVEMENT ON MACHINES

Ensure enrollers (black cone plastic) are in tight to bale, the bale will reduce in size during wrapping, the corner will become rounded then the bale will tend to move sideways due to central fugal force, if the rollers are too far apart the bale will move against one end, causing the belt to move in the opposite direction, always adjust the belt or end cone rollers, so they keep the bale central on the belt.

On trailed machines adjust bale stop on the lift arm so that the bale is loaded centrally on the belt.

Check that the grip-face are securely fixed to the drive roller.

Check that the belt is the same measurement at each side, if one side is longer than the other then replace the belt.

IF THE PROBLEM STILL OCCURS REMOVE THE CHAIN COVER,

1. Adjust chain so that the chain is at the correct tension
2. Measure the distance between the bearing housing and the adjuster plate (typically from 13 to 19 mm)
3. Adjust the opposite end of the driver roller to archive the same measurement.
4. Now you will find that the driver roller is parallel to the chasse.
5. Set idler roller square to driver roller, set from bearing housing to adjusting stop, it should be about 15mm at the start position.
6. If the drive belt is moving to the chain drive side, you will need to make a deeper well at the opposite end.
7. To create this deeper well first stand facing the turntable at the end of the machine with the chain at the bottom right hand corner, this corner at the chain drive is 'A' the top of the drive roller at the other end is 'B' the top of the idler at other end is 'C' and the bottom of the idler at your left is 'D'.
8. Now adjust point 'C' inward by 10mm
9. If the problem still occurs adjust point 'D' outwards by 2mm at any one time.
10. When any one adjustment is made you may have to wrap a minimum of 5 new fresh bales full cycle before making any further adjustments.

If making any more adjustments move only 2mm at one time and wrap 5 bales through full cycle.



17. Warranty claim form

Customer details

Name & address;

Contact number and Name

Date & dealer details purchased from;

/ /

Fault reported / work requested;

Work carried out;

Additional work required

Parts used

Part number or description Qty Cost

Costs incurred

Miscellaneous costs

Total

=

Labour

Hrs X =

Parts cost

=

Grand total

=

Warranty Y /N ____ Claim No _____



18. EC DECLARATION OF CONFORMITY

ACCORDING TO DIRECTIVES 89/392/336/EEC AS AMENDED

Manufacture: TANCO ENGINEERING CO LTD
BAGENALSTOWN
CO CARLOW
IRELAND

CERTIFIES THAT THE FOLLOWING PRODUCT:

AUTOWRAP

MODEL: 580-A

SERIAL NO.:

To which this declaration relates, corresponds to essential requirements of the Directive 89/392/336/EEC as amended.

To conform to these essential health and safety requirements, the provisions of the following harmonised standards were particularly considered:

EN 292 – 1,2, EN 294, EN1152, prEN 703, prEN 811, prEN 1553, prEN 982.

DATE: 02/09/03

SIGNATURE: _____
ANDREW DEASY
TECHNICAL MANAGER